

R2CH20



DP051015bH



R2CH20

Rimorchio  
Trailer



**A.R.I.S.** spa  
Applicazioni Rielaborazioni Impianti Speciali  
strada Cascina Bertola 10 - regione Poligono  
10040 Lombardore - Torino - Italy  
tel +39 011 9956150  
fax +39 011 9956205  
[www.aris-spa.it](http://www.aris-spa.it)  
[info@aris-spa.it](mailto:info@aris-spa.it)

Le informazioni riportate sono a titolo informativo. La società A.R.I.S. SpA si riserva di variarle in qualunque momento, senza preavviso. La riproduzione, anche parziale, è vietata.  
Information contained in this document is to be considered company commercial sensitive.  
Disclosure to third parties or reproduction, even partial, is not allowed. Specification subject to change without notice.





## R2CH20

**R2CH20** è un rimorchio a 2 assi sterzante su ralla, progettato per soddisfare i requisiti di trasporto di container unificati tipo ISO 1C (20'), o carichi vari uniformemente distribuiti.

- |          |                          |          |
|----------|--------------------------|----------|
|          | Caratteristiche tecniche |          |
| - masse: | tara                     | 3500 kg  |
|          | portata                  | 16500 kg |
|          | mtt                      | 20000 kg |
- telaio con struttura monolita composta da longheroni e traverse in acciaio ad altissima resistenza, uniti mediante elettrosaldatura; nella parte inferiore, sono previsti opportuni anelli per il trasporto ferroviario e marittimo
  - pianale di carico in lamiera mandrolata, twist-lock a scomparsa per il trasporto di container unificati tipo ISO 1C (20'), calzatoie, 8 golfari a scomparsa per l'ancoraggio dei carichi trasportati e dispositivo "alza e abbassa" per la regolazione pneumatica dell'altezza del piano di carico
  - sospensioni pneumatiche su gli assi con ammortizzatori telescopici e balestre
  - timone con occhio di traino
  - impianto freni di tipo pneumatico, continuo e automatico. Freno di stazionamento pneumatico e freno di emergenza meccanico
  - impianto elettrico 24 V.

**R2CH20**: two-axle fifth wheel steering trailer designed to meet requirements for transportation of ISO 1C (20') containers or evenly distributed loads.

- |           |                    |  |
|-----------|--------------------|--|
|           | Technical features |  |
| - Tare    | 3500 kg            |  |
| - Payload | 16500 kg           |  |
| - GVW     | 20000 kg           |  |
- Monolithic structure chassis made by electro welded high resistance steel side frame and frame cross members; rings suitable for rail and maritime transport fixed on the lower part of the chassis
  - Treadplate loading bed, retractable twist-lock suitable for transportation of ISO 1C (20') containers, wedges, 8 retractable fasteners for load fixing during transportation; "up/down" device for pneumatic height adjustment of the loading bed
  - Pneumatic suspensions on all axles with telescopic shock absorbers and leaf springs
  - Drawbar equipped with towing eye
  - Continual and automatic pneumatic brake system; pneumatic parking brake and mechanic emergency brake.
  - 24 V Electrical System .



# R2CH20

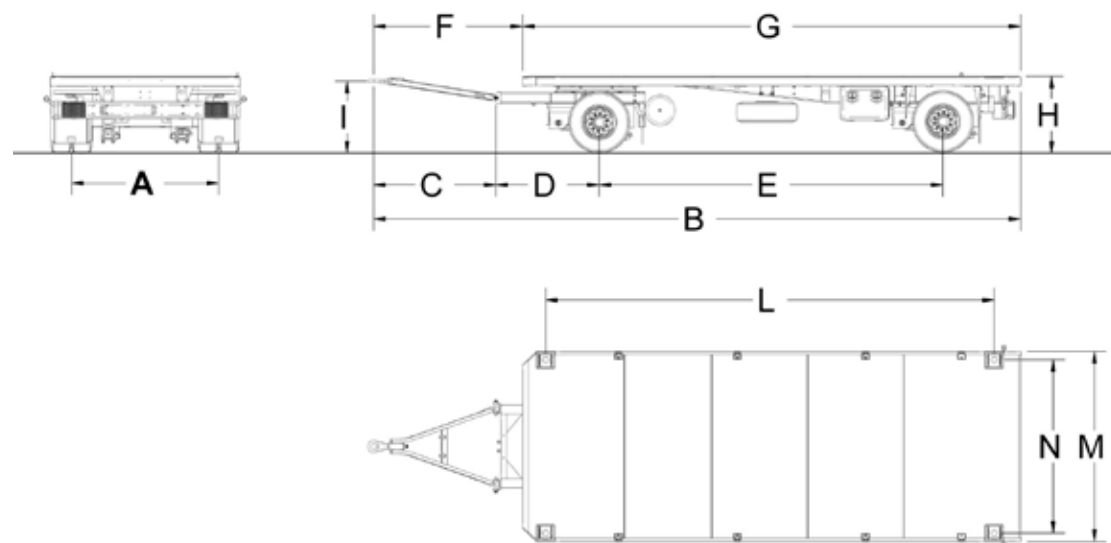

A	1920 mm	B	8442 mm	C	1600 mm	D	1345 mm	E	4485 mm	F	1945 mm
G	6500 mm	H	910 - 987 mm	I	937 mm	L	937 mm	M	2475 mm	N	2259 mm

